

BRISTAN

TAPS & SHOWERS

Installation Instructions & User Guide

Please leave these instructions with the end user

Product code: VRT BASNW C (D1)

Specifications

Dynamic Water Pressure

Min: 0.3bar Max: 5.0bar

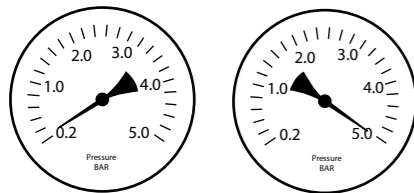

Maximum Static Pressure: 10.0bar

Inlet water temperature

Cold Water Supply

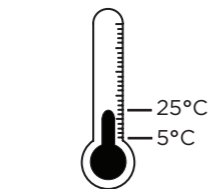

Min: 5°C Max: 25°C

Hot Water Supply

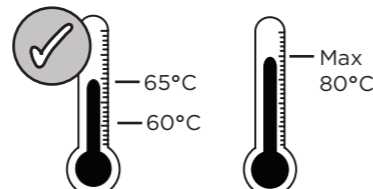

60-65°C Recommended 80°C Maximum

Inlet Connections

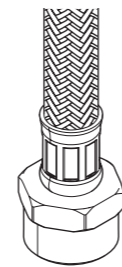

15mm Female Compression Fitting

Tools you'll need

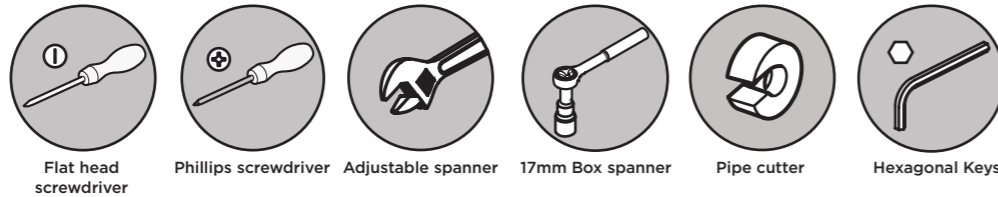

Prior to Installation

All products manufactured and supplied by Bristan are safe provided they are installed, used correctly and receive regular maintenance in accordance with this instruction.

This product needs to be installed in accordance with, and meet the requirements of the Water Supply (Water Fittings) Regulations 1999 and Scottish Bye-laws 2004.

For product specific installation requirements, please visit www.wras.co.uk

Isolation valves must be fitted to the inlet water supplies to ensure ease of future maintenance.

Before installing this product the water supply must be thoroughly flushed in order to remove any swarf, solder etc.

This product must not be modified in any way as this will invalidate the guarantee.

Full access must be made available for future maintenance / servicing purposes.

If in doubt, contact a registered plumber or your Local Water Authority or the Secretary of the Institute of Plumbing, address as follows:-

The Institute of Plumbing,
64 Station Lane,
Hornchurch,
Essex,
RM12 6NB, Tel: 01708 472791

Pack Contents

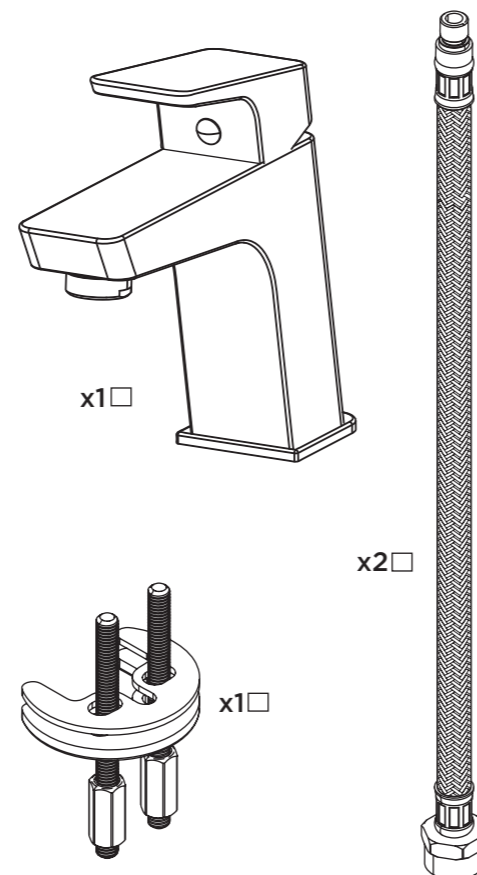

Flexible Connecting pipes

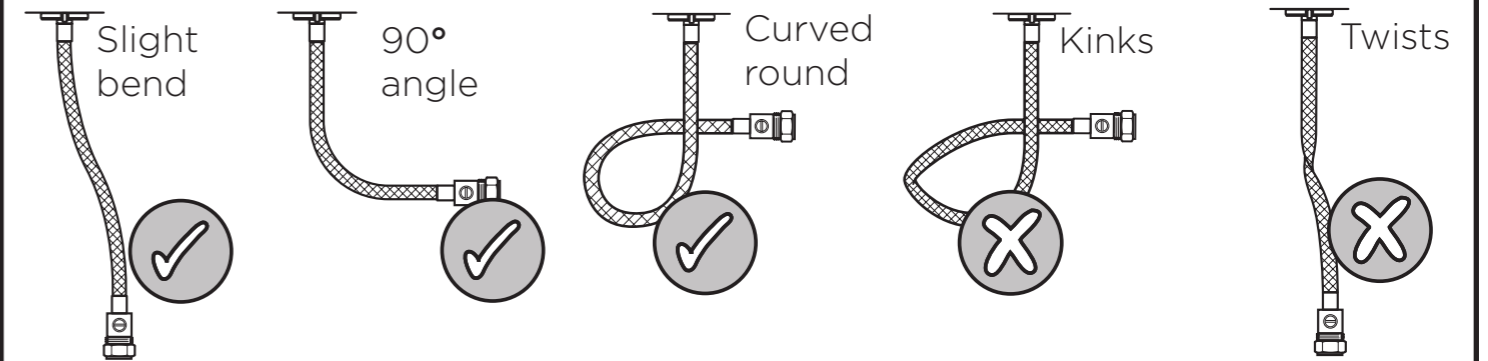

Installation

1

Screw the flexi tails into the bottom of the mixer body. (Do not overtighten)

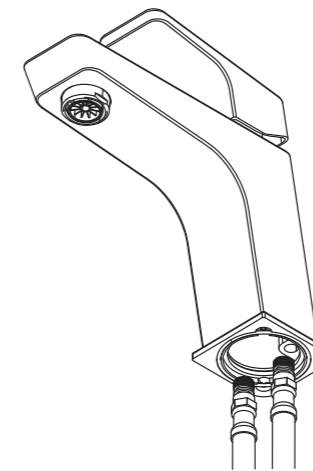

2

Feed the flexi tails through the hole in the basin.

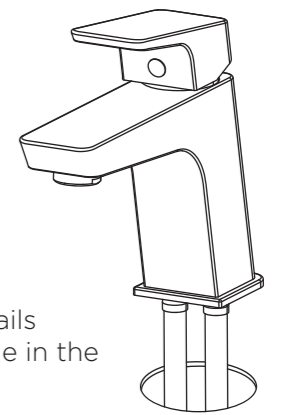

3

Slide the 'C' shaped rubber washer and the 'C' shaped metal washer onto the fixing rods up to the underside of the basin. To secure the mixer in place tighten the fixing nuts onto the fixing rod until they fully tightened against the 'C' shaped metal washer.

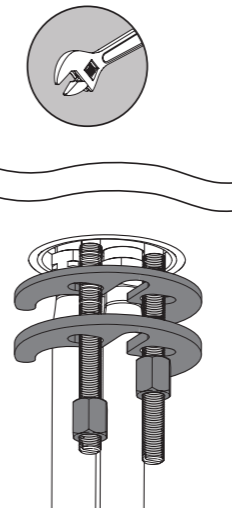

4

Connect the flexi tails to the hot and cold water supplies. Turn on the mains water supply letting the water flow for a few minutes to flush through the system. Check all joints and connections for any leaks.

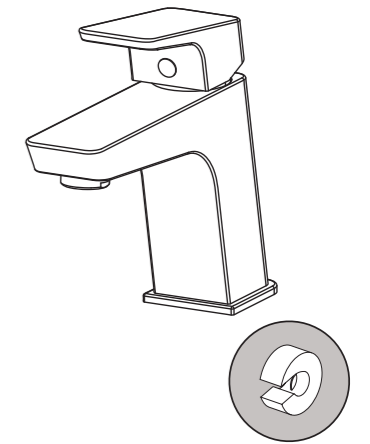

Why not visit our YouTube channel

To see our latest how-to videos, simply scan the QR code with your smart phone or tablet.

Alternatively visit www.youtube.com/bristantv



Operation

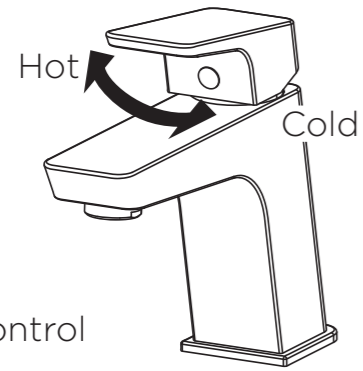

Temperature Control

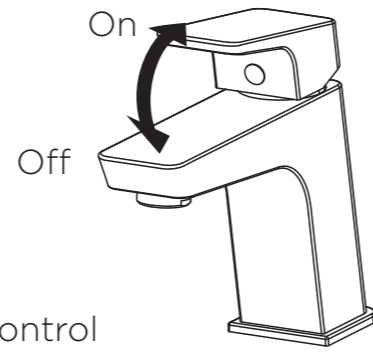

Flow Control

Maintenance - Cartridge Cleaning

1

Prior to doing any maintenance or servicing, isolate the water supply to the basin mixer.

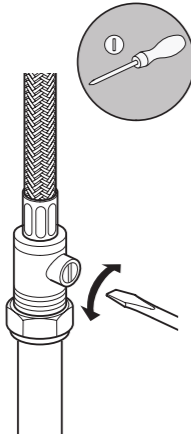

2

Remove the cap and loosen the grub screw.



3

Remove the shroud.

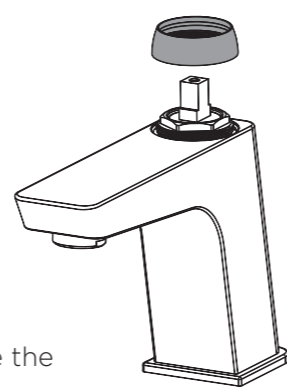

4

Remove the cartridge retaining nut using suitable spanner.

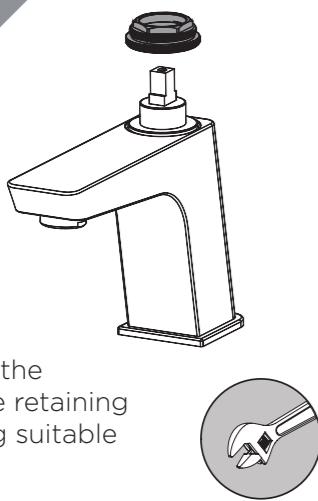

5

Remove the cartridge and clean thoroughly under cold water to remove any build up of lime-scale or debris.

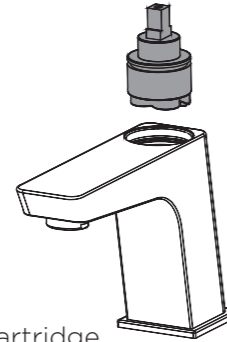

6

Replace the cartridge into the body. Tighten the cartridge retaining nut using suitable spanner.

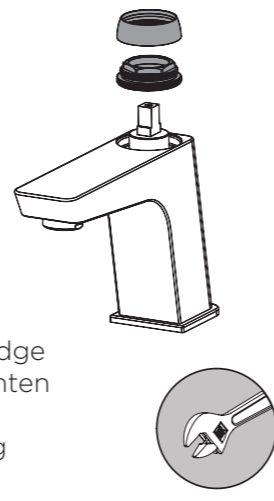

7

Replace the handle, tighten the grub screw and push fit the cap

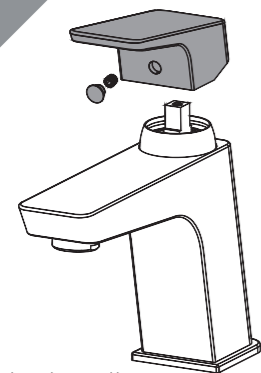

8

Turn the water supply on.

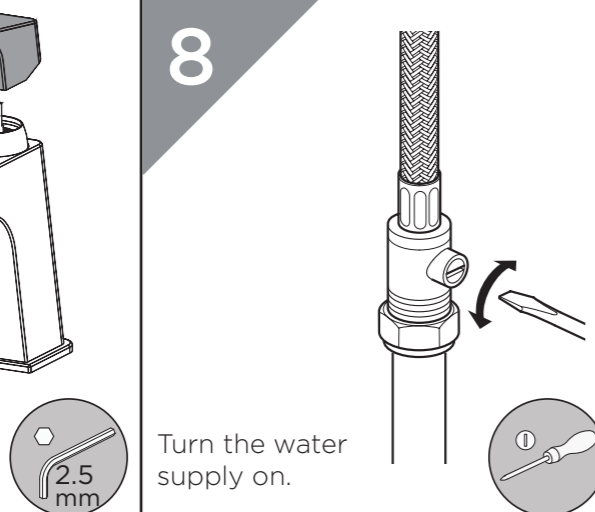

Maintenance - Aerator

1

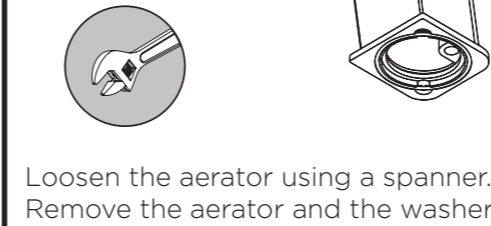

Loosen the aerator using a spanner. Remove the aerator and the washer.

2

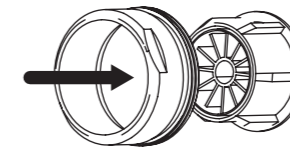

Separate the aerator from the collar by pushing it out of the threaded end of the collar.

3

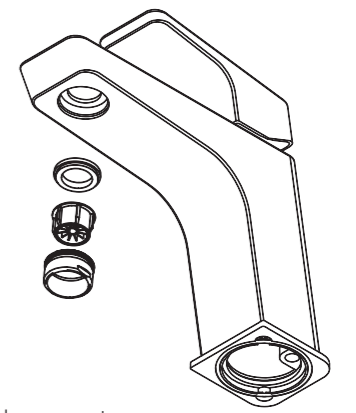

Replace the aerator, ensuring the washer has been fitted. Secure in place by tightening with suitable spanner.

General Cleaning

Your fitting has a high quality finish and should be treated with care to preserve the visible surfaces.

All surfaces will wear if not cleaned correctly, the only safe way to clean your mixer tap is to wipe with a soft damp cloth. Stains can be removed using washing up liquid. All bath cleaning powders and liquids will damage the surface of your fitting, even the non-scratch cleaners.

Note: Never use abrasive detergents or disinfectants or those containing alcohol, hydrochloric acid or phosphoric acid.

Troubleshooting

Symptom	Cause	Remedy
No flow or low flow rate	partially closed isolation valve.	Open isolation valve.
	Instantaneous water heater cycles on and off as flow rate or pressure is too low.	Increase water flow rate or pressure through system.
	Head of water is below the minimum distance required.	2 meters minimum required.
	Hot or cold water being drawn off elsewhere causing pressure changes or instantaneous boiler temperature changes.	Do not use other water outlets when using the taps.
	Air lock or partial blockage in the supply pipe work.	Flush through pipe work to ensure removal of debris and any air locks.
Water dripping from taps	This is normal for a short time after using the taps.	This is caused by capillary action, the build up of water in the tap body.
	If water continues to drip, possibly due to the ceramic disc valves	Remove valves and clean, refer to 'Maintenance' section before starting any maintenance.
Taps do not turn on	Closed isolation valve.	Open isolation valve.
	Mains water supply turned off.	Turn on mains water supply.

Spare Parts

To replace any spare parts for your bath shower mixer why not scan the QR code and search for your product



At Bristan, we want to make things as easy as possible for our customers. That's why we offer solid guarantees on all our products, effective from the date of purchase, to give you peace of mind.

To start your free **guarantee** simply scan the QR code and register your product, alternatively visit www.bristan.com/register.

For any other queries, please call our Customer Service on 03300266273 where our expert team of advisors will be able to offer you any help and advice.

For full guarantee terms and conditions visit www.bristan.com/guarantees.



We Know & We Care